

CUBICLE ROW COOLER / CONTAINER COOLER CRANEFRIGOR™ CK20.1

MODEL CODE CK20

TYPE	COMPRESSOR	REFRIG.	CURRENCY / FREQUENCY
CK20.1	S1	34	400V50Hz

TYPE	CONTAINER COOLER
COMPRESSOR SIZE	S = SCROLL
REFRIGERANT	R134a
POWER SUPPLY	3 Ph 400V / 50Hz 3 Ph 460V / 60Hz

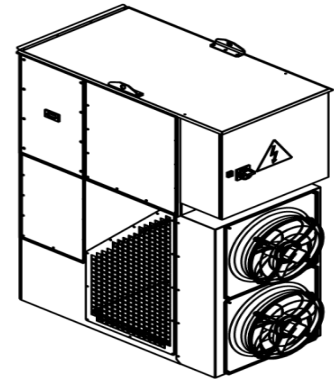

GENERAL DATA CK20

TYPE	CK20		
AIR FLOW NOMINAL	[m³/h]	6.000	
CIRCULATING AIR FILTER	Z-Filter	G4	
DIMENSIONS	HIGHT	[mm]	2.290
	WIDTH	[mm]	800
	DEPTH	[mm]	1.620
WEIGHT	[kg]	590	
AMBIENT TEMP.	MIN. / MAX.	[°C]	-25 / 60

NOMINAL COOLING CAPACITY CK20-S2-34-400V50Hz

Different cooling capacities possible with other compressors / layouts

COOLING CAPACITY [kW]	FREQUENCY [Hz]	AMBIENT TEMPERATURE [°C]		
		30	45	55
25	50 + 60	20,2	16,9	14,7
30	50 + 60	23,4	19,3	17,0
35	50 + 60	26,2	21,7	19,1

EXEMPLARY APPLICATION:

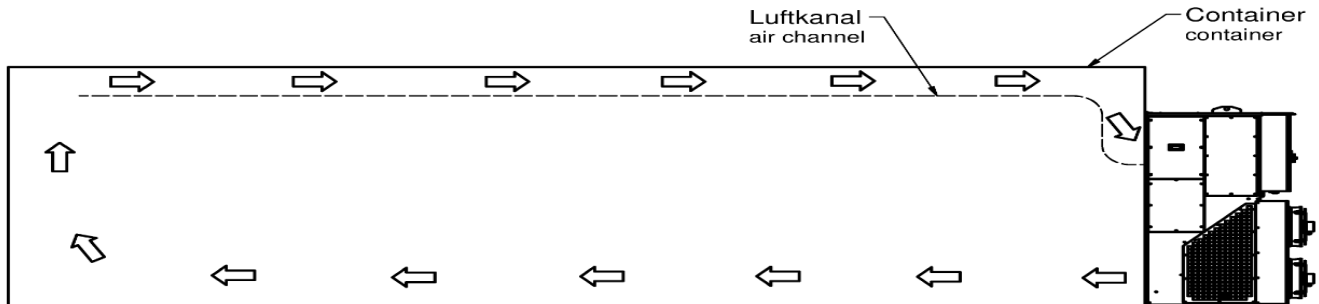

- 1) ALL SPECIFICATIONS AND INFORMATION SUBJECT TO CHANGE BY THE MANUFACTURER
- 2) ALL UNITS ARE SUBJECT TO THE FRIGORTEC QUALITY STANDARDS AND ARE ONLY DELIVERED AFTER INTENSE TEST RUN.
- 3) VALUES AND STANDARDS ACCORDING TO DIN EN 12900, DIN9873, DIN8976 AND EN ISO3744
- 4) INFORMATION AND TOLERANCES ARE ACCORDING TO DIN EN 12900, DIN9873, DIN8976 AND EN ISO3744